

Shibaura Machine

Regeneration Discharge Unit Instruction Manual

This instruction manual describes the regeneration discharge unit made by our company. All users are requested to completely read through and understand this manual before use, and to handle the unit with utmost care.

Keep this manual for future reference.

1. Application

The regeneration discharge unit is intended for absorbing energy in its circuit, which is generated at slowdown of the actuator motor. It is very useful when load inertia is expected to exceed the permissible value or when generation of too much energy is expected, and prevents generation of overvoltage in the robot controller.

2. Specifications

| Type | ABSU-1000 | ABSU-2000 | Remarks |
|--------------------------------|--|--|--|
| Regeneration operating voltage | DC190 V | DC420 V | |
| Protection function | The thermo-relay operates when the discharge resistor temperature has reached 150°C. | | Contact capacity AC125 V, 4 A AC250 V, 4 A |
| Applicable controller | CRLAC-B1A* CM2AC-B2A* | CA25-M10/S10 CA20-M10/S10 CA10-M10/S10 | *: Volt specification is displayed by 1 to 7 |
| Environmental conditions | | | |
| • Place of installation | Indoor | | |
| • Operating temperature | 0°C ~ 40°C | | |
| • Operating humidity | 30 % ~ 90 %RH, non-condensing | | |
| • Operating atmosphere | No corrosive gas is involved. | | |
| • Storage temperature | -20°C ~ 70°C | | |
| • Storage humidity | 30 % ~ 90 %RH, non-condensing | | |
| • Storage atmosphere | No corrosive gas is involved. | | |
| • Vibration | 9.8 m/S ² or less | | |
| Outer dimensions | 55 (W) × 160 (H) × 122 (D) | | Including cooling fan and excluding fixture. |
| Mass | 0.78 kg | | |

Caution: When the regeneration discharge unit is used together with a controller other than the controller specified above, the unit may malfunction or may not operate at all. Especially, if ABSU-1000 is used for CA controller, it malfunctions immediately.

3. Outer Dimensions

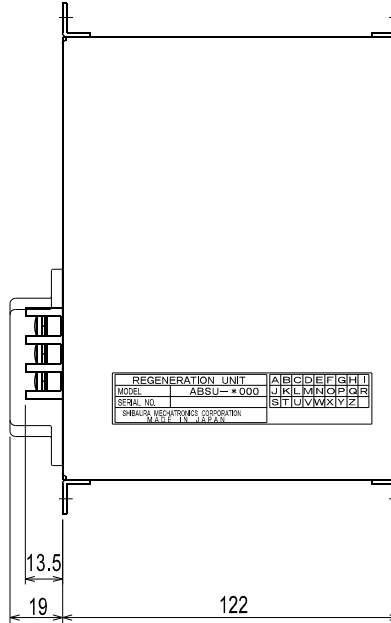
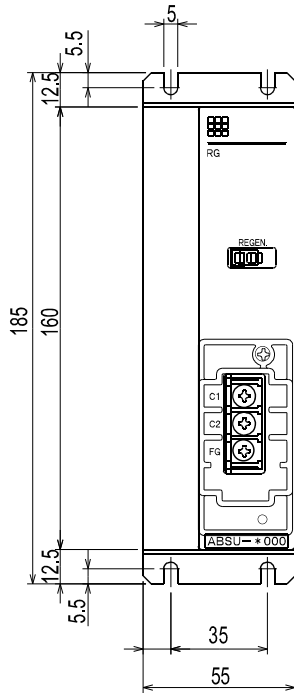

4. Installation

This equipment employs the nature air cooling system using convection.

Be sure to install it lengthwise, keep enough spaces as shown in the drawing below not to blockade the vent holes on the top and bottom sides. If ventilation is incomplete, the equipment cannot be operated to its full capacity and will cause a trouble.

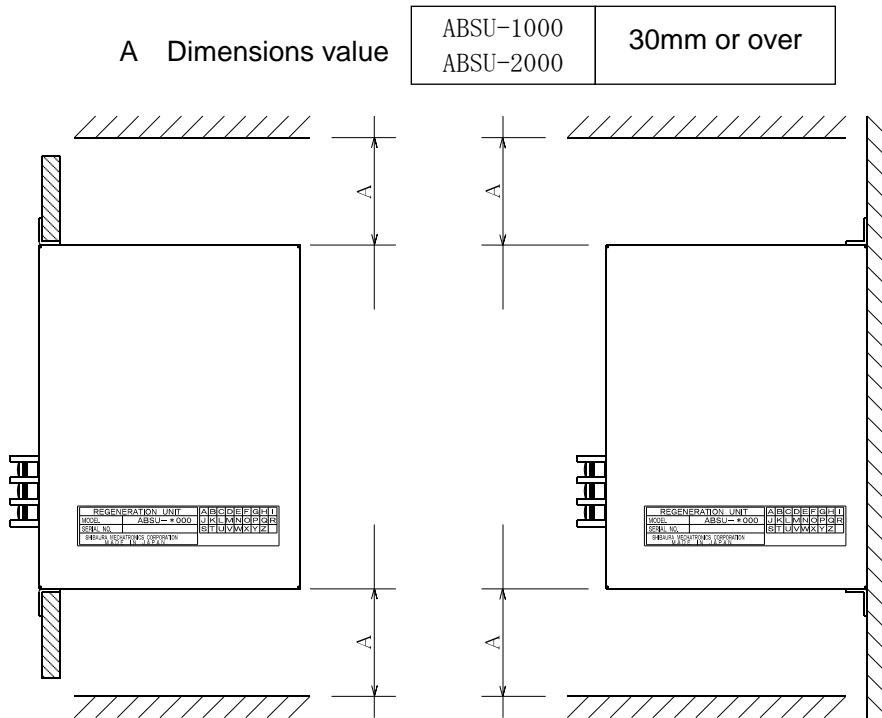

Take careful precautions to prevent entry of contaminant such as liquid and dust into the regeneration discharge unit from the vent holes.

This equipment is not dust-proof. Avoid using it in a heavily contaminated place.

5. Example of Connection

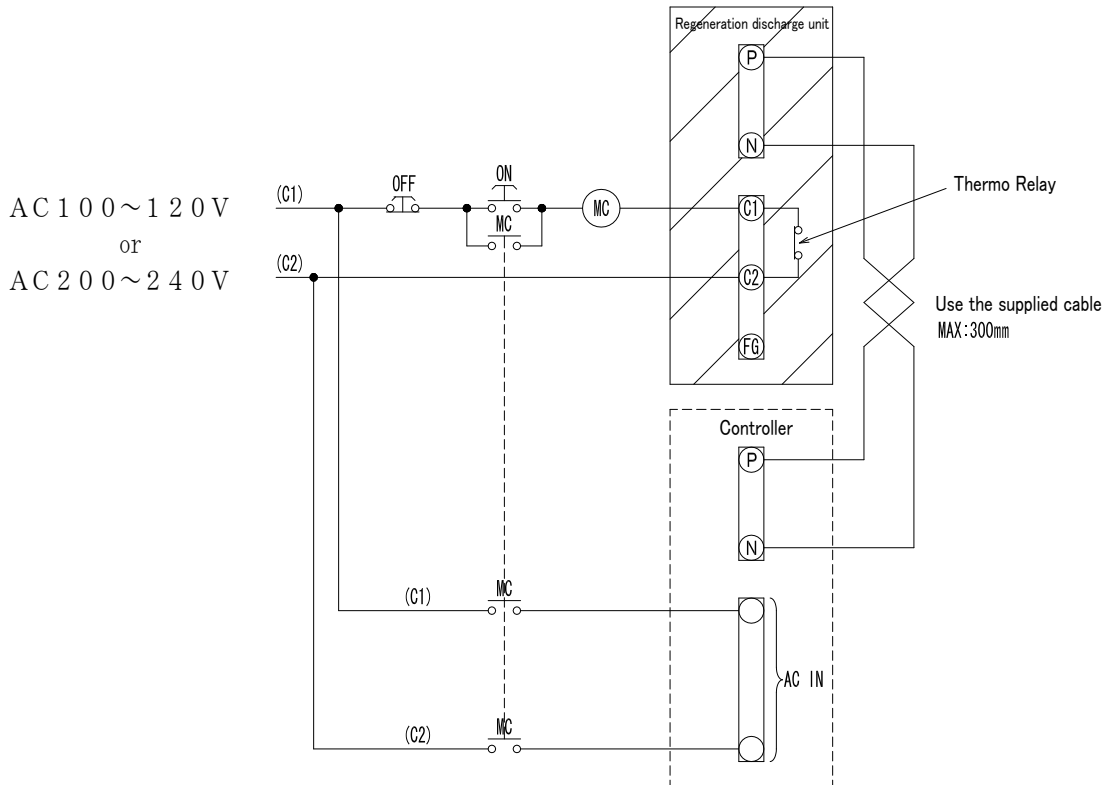

6. Cautions on Use

- A thermo-relay is incorporated in the discharge resistor of the regeneration discharge unit, which operates when the discharge resistor temperature reaches 150°C.
- When this relay has actuated, output terminals C1–C2 of the regeneration discharge unit become open.
- Create the sequence in such a manner that when the thermo-relay has actuated, the controller always stops.
- Once the thermo-relay has actuated, it takes about three (3) minutes until it is reset (i.e., restored to a normal state).

7. How to Use Attached Terminal Block Cover

After wiring to the terminal block, be sure to set the attached terminal block cover to prevent electric shocks.

Use the terminal block cover by processing after confirming the wire lead-in direction, as shown below.

Terminal block cover (transparent)

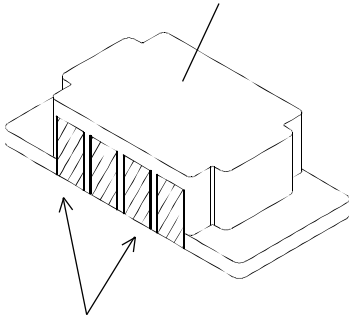

Make a cut along the thick lines, then bend the shaded areas.

To provide lead-in wire holes, remove the shaded areas in the left figure, using nippers (or a cutter) when necessary. It is also possible to provide these holes on the opposite side.