

BTD-200QH

Shibaura Machine



BTD-200QH

FLEXMACHINE

Shibaura Machine

View the Future with You



ISO 9001



GOTEMBA plant

SHIBAURA MACHINE CO., LTD.

TOKYO MAIN BRANCH
2-2, Uchisaiwaicho 2-Chome, Chiyoda-ku, Tokyo 100-8503, Japan
TEL:+81-3-3509-0271 FAX:+81-3-3509-0335

SHIBAURA MACHINE CO., AMERICA

Chicago Head Office
755 Greenleaf Avenue, Elk Grove Village, IL 60007, U.S.A.
TEL:847-709-7199 FAX:847-593-9741

Canada Branch

6 Shields Court, Suite 101, Markham, Ontario L3R 4S1, CANADA
TEL:905-479-9111 FAX:905-479-8339

SHIBAURA MACHINE UK LTD.

66 Burners Lane, Kiln Farm, Milton Keynes MK11 3HD
UNITED KINGDOM
TEL:+44-(0)1908-562327 FAX:+44-(0)1908-562348

SHIBAURA MACHINE SINGAPORE PTE. LTD.

Head Office
123 Pioneer Road, Singapore 639596, SINGAPORE
TEL:68611455 FAX:68612023

TOSHIBA MACHINE [THAILAND] CO., LTD.

127/28 Panjathanee Tower, 23rd Floor, Nonthree Road, Khwaeng Chong
Nonthree, Khet Yannawa, Bangkok 10120, THAILAND
TEL:02-681-0158 FAX:02-681-0162

TOSHIBA MACHINE [VIETNAM] CO., LTD.

2nd, VIT Tower, No.519, Kim Ma Street,
Ba Dinh District, Hanoi, VIETNAM
TEL:024-2220-8700,8701 FAX:024-2220-8702

TOSHIBA MACHINE (CHENNAI) PRIVATE LIMITED

No. 65 (P.O. Box No. 5), Chennai-Bangalore Highway, Chembarambakkam,
Poonamallee Taluk, Thiruvallur, Chennai-600123, Tamil Nadu, INDIA
TEL:044-2681-2000 FAX:044-2681-0303

SHIBAURA MACHINE TAIWAN CO., LTD.

No.62, Lane 188, Jui-Kuang Road, Nei-Hu District, Taipei, TAIWAN
TEL:02-2659-6558 FAX:02-2659-6381

SHANGHAI TOSHIBA MACHINE CO., LTD.

Head Office
4788, Jin Du Road, Xinzhuang Industry Zone, Shanghai, 201108
PEOPLE'S REPUBLIC OF CHINA
TEL:021-5442-0606 FAX:021-5866-2450

* We reserve the right to change any of specifications in this catalog without notice in order to effect improvements.

Highly Preferred FLEXMACHINE

Supported by many users from generation to generation.
Easy-to-use and equipped with new features supporting more advanced machining operations.

FLEXMACHINE BTD-200QH

Main features

1. Easy-to-operate compact pendant for manual machining operations.
2. Best suited for face milling and end milling operations.
3. Most sophisticated CNC system TOSNUC 999.
4. NC rotary milling function (option) which allows four-axis control in lieu of current three-axis control.
5. Enhanced productivity with spindle of 5000 min⁻¹ speed (option).

Main specifications

		BTD-200QH
Table working surface	mm (in)	1 000×1 200 (39.3×47.2)
Table loading capacity	kg (lbs)	4 000 (8 800)
Axis travel	X mm (in)	1 500 (59.0)
	Y mm (in)	1 200 (47.2)
	Z mm (in)	700 (27.5)
	W mm (in)	400 (15.7)
Minimum indexing angle of table	B deg	0.0001°
Spindle speed	min ⁻¹	20~3 000 [15~5 000]
Spindle drive motor	kW (HP)	AC30/22 (AC40/30)
Tool storage capacity		30 [60, 90]

Note: Values in brackets [] refer to the options.



Photo shows with options.



Quill at 400 mm extended (W-axis)

Fully extended 200 mm-diameter quill type shown at 400 mm maximum.

Spindle capable of powerful cutting with quill extended at 400 mm.

Spindle torque/output power diagram (standard specification) 3000min⁻¹

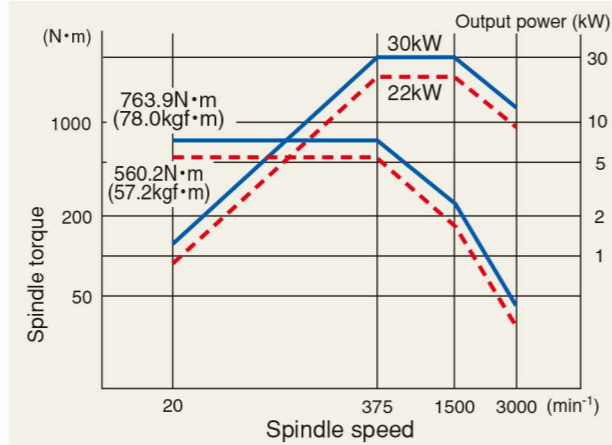

Wide table withstand heavy load and allows easy set-up.

The table as wide as 1 000 × 1 200 mm has a standard maximum load mass of 4 tons. Thus, enabling the set-up of work-pieces with longer widths.



B-axis drive mechanism provides high-speed and high-accuracy machining.

Use of the highly rigid double-pinion drive system and standard rotary scale emphasizes stable high-speed and high-accuracy table indexing operations.

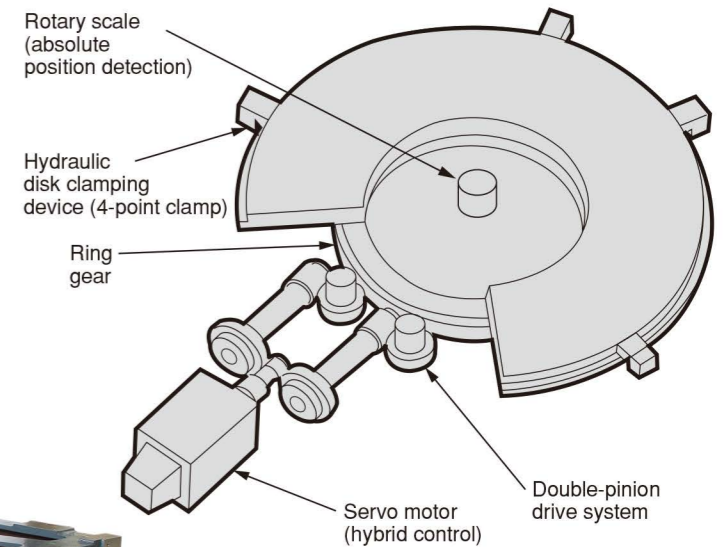

Face milling ability (workpiece material: AISI 1055)

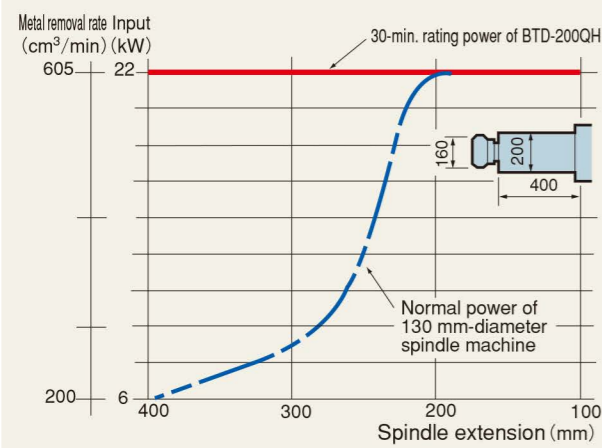

Spindle torque/output power diagram (option) 5000min⁻¹

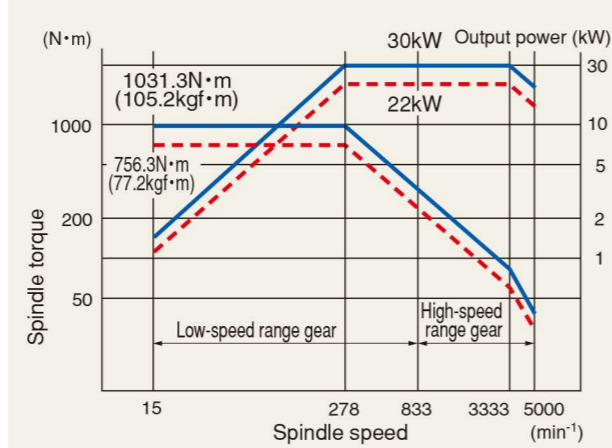

High rigidity bed supports the entire machine.

The new integrated type 4-way structure bed minimizes influences of load fluctuations caused by the movements of saddle and table, and maintains machining accuracy even at heavy-duty cutting operations.

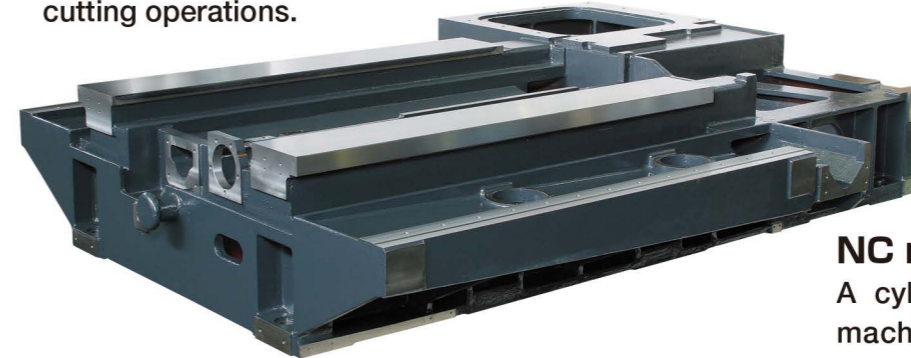

NC rotary milling operation (option)

A cylindrical surface and end surface can be machined continuously by using the B-axis continuous indexing function of the table without using a special independent NC rotary table. Easily create an NC program for the cylindrical surface using the cylindrical interpolation function (G67).

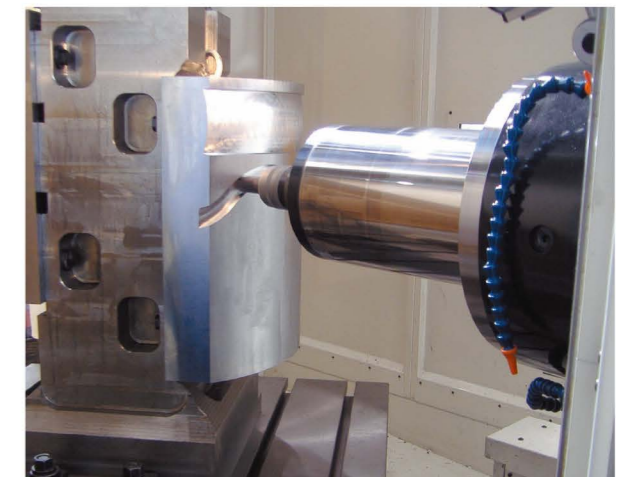

An example of cutting ability (workpiece material: AISI 1055)

	Cutter dia. mm (in)	Cutting speed m/min (fpm)	Spindle speed min ⁻¹	Feedrate mm/min (ipm)	Width of cut mm (in)	Depth of cut mm (in)	Metal removal rate cm³/min (in³/min)	W-axis extension mm (in)
Face milling	160 (6.3) dia. No. of flutes:8	125 (400)	250	840 (33.1)	120 (4.7)	6 (0.2)	605 (36.9)	400 (15.7)
End milling	80 (3.1) dia. No. of flutes:6	100 (328)	400	720 (28.3)	20 (0.8)	50 (2.0)	720 (43.9)	400 (15.7)
Large-diameter boring	φ392	110 (361)	90	26 (1.0)	—	6 (0.2)	189 (11.5)	400 (15.7)
Drilling	φ69.5	22 (72.2)	100	50 (2.0)	—	—	—	—
Tapping	M60×P5.5	10 (32.8)	53	291.5 (11.7)	—	—	—	—
Tapping	M4×P0.75	8 (26.2)	640	480 (18.9)	—	—	—	—

* The above cutting data may differ with each machine, fixtures, machining position, cutter, holder, etc.
* The above cutting data refer to the 3,000 min⁻¹ spindle.

5 000 min⁻¹ spindle with high-speed and high-torque specifications (option)

The mechanical two-stage gear change system with high-speed and high-torque 5 000 min⁻¹ spindle can cope with more extensive machining operations, exceeding the current high-rigidity quill structure.

Machine Specifications

Main machine specifications (standard)			BTD-200QH		
			Standard	with APC	
Travel	X-axis travel (Cross movement of table)	mm (in)	1 500 (59)		
	Y-axis travel (Vertical movement of spindle head)	mm (in)	1 200 (47.2)	1 000 (39.3)	
	Z-axis travel (Longitudinal movement of table)	mm (in)	700 (27.5)		
	W-axis travel (Quill extension)	mm (in)	400 (15.7)		
	Distance from table surface to spindle centerline	mm (in)	0~1 200 (0~47.2) 0~1 000 (0~39.3)		
	Distance from table centerline to spindle gage plane	mm (in)	450~1 150 (17.7~45.2)		
Table	Table working surface	mm (in)	1 000×1 200 (39.3×47.2)		
	Table loading capacity	kg (lbs)	4 000 (8 800)	3 500 (7 700)	
	Table surface configuration (Pitch of T-slots: 160 mm)	mm (in)	6 T-slots, size 22, pitch 160 (size 0.86, pitch 6.2)		
	Minimum table indexing angle	deg	0.0001°		
Spindle	Rotating spindle diameter	mm (in)	110 (4.33)		
	Extended quill diameter	mm (in)	200 (7.8)		
	Spindle speed	min ⁻¹	20~3 000 [15~5 000]		
	Number of spindle speed ranges		1 range [2 ranges]		
	Type of spindle taper hole		7/24 taper No.50		
Feedrate	Rapid traverse rate	X,Y,Z	mm/min (ipm) 12 000 (472.4)		
		W	mm/min (ipm) 5 000 (196.8)		
		B	deg/min 1 080		
	Feedrate	X,Y,Z	mm/min (ipm) 1~6 000 (0.039~236.2)		
Automatic tool changer	Type of tool shank		MAS BT50		
	Type of retention knob		MAS P50T-1 (45 degree)		
	Tool storage capacity		30 [60, 90]		
	Maximum tool diameter	When pots are full	mm (in)	125 (4.92)	
		When adjacent pots are empty	mm (in)	240 (9.44)	
	Maximum tool length		mm (in)	400 (15.74)	
Maximum tool mass		kg (lbs)	25 (55)		
Method of tool selection			Pot address random short-cut		
Spindle drive motor	(30-min. rating/cont. rating)	kW (HP)	AC30/22 (AC40/30)		
Power sources	Electric power supply		AC200/220V±10%, 50/60Hz±2%		
	Power capacity	kVA	68	72	
	Compressed air supply	Pressure	Mpa [kgf/cm ²] (psi)	0.5~0.8 {5~8} (82.5~116)	
Flowrate		Nℓ/min	150		
Machine size	Machine height	mm (in)	3 210 (126.4)		
	Floor space	mm (in)	4 400×4 430 (173.2×174.4)	4 870×6 690 (191.7×263.4)	
	Mass of machine (including CNC system)	kg (lbs)	18 000 (39 600)	23 000 (50 600)	
Accuracy	Positioning accuracy	X,Y,Z	mm (in) ±0.005/full length (±0.00019/full length)		
		X,Y,Z (with scale)	mm (in) ±0.003/full length (±0.00011/full length)		
		W	mm (in) ±0.012/full length (±0.00047/full length)		
	Repeatability	X,Y,Z	mm (in) ±0.003 (±0.00011)		
		X,Y,Z (with scale)	mm (in) ±0.002 (±0.00007)		
		W	mm (in) ±0.008 (±0.00031)		
Table indexing accuracy (arbitrary angle)		±3"			
Table indexing repeatability (arbitrary angle)		±1.5"			
Exterior painting color			R4-383 (Munsell Y8.4/0.5) and N2.5 (For CNC system, servo motors and cooler, each maker's standard color shall apply.)		

Note: Values in brackets [] refer to the options.
The values in the specifications table above indicate the maximum capacity. If a continuous long-hour operation is required at the maximum capacity, please consult with us beforehand.

Machine External View

BTD-200QH

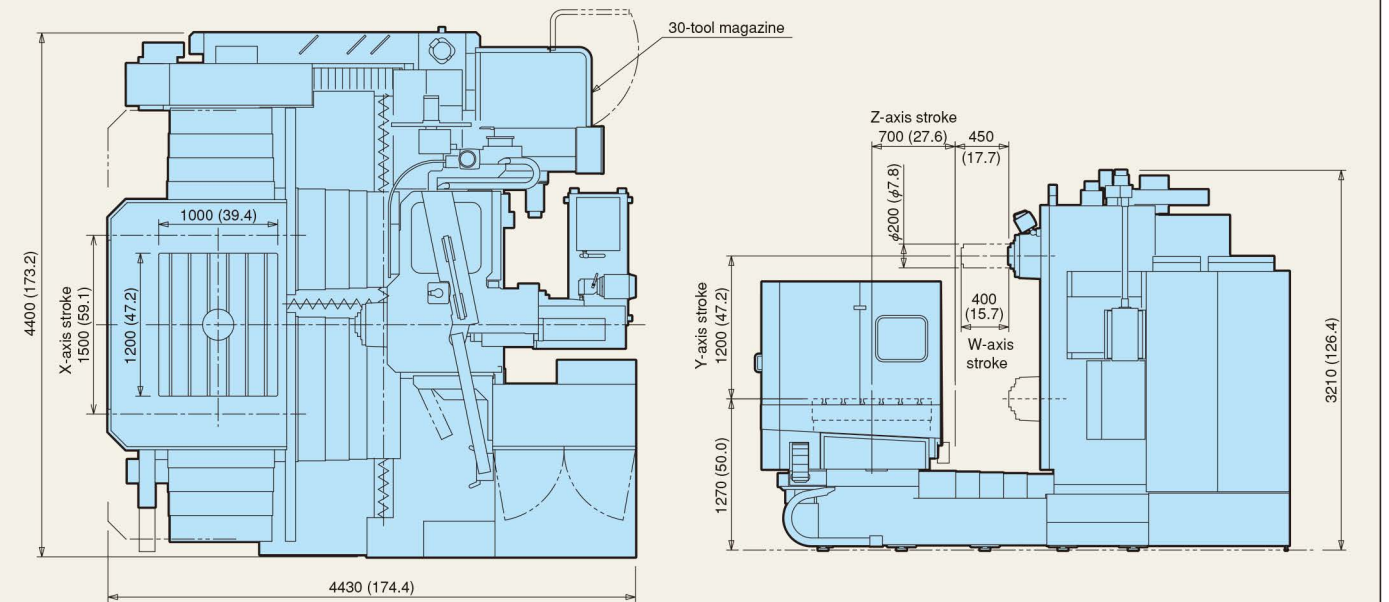

BTD-200QH (APC)

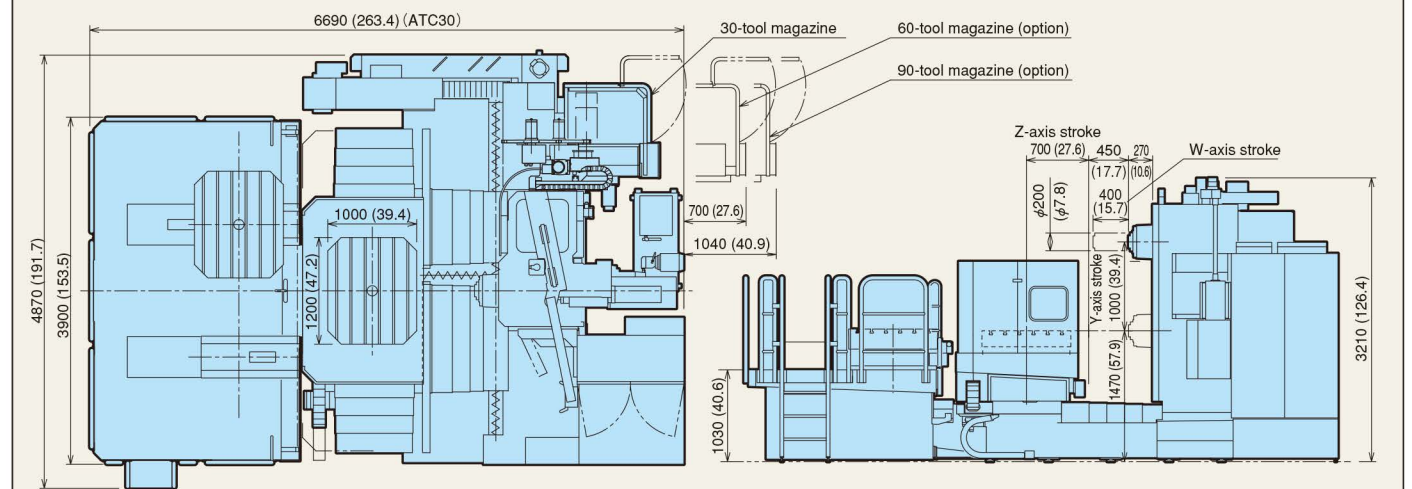
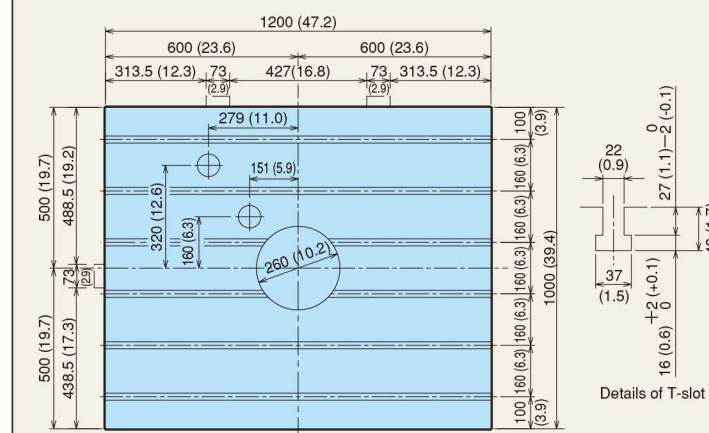
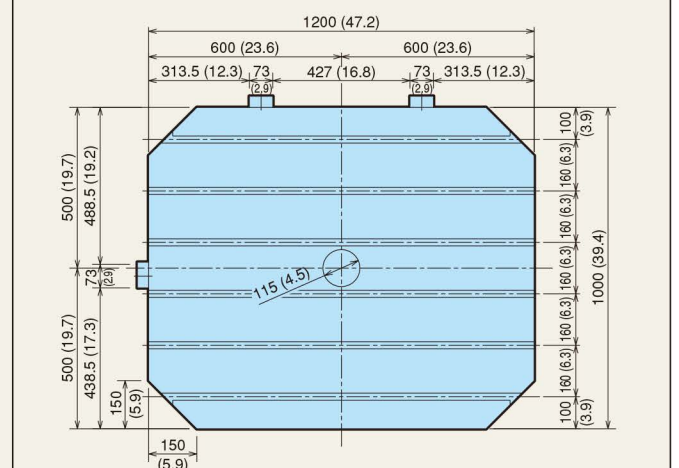

Table Top View

BTD-200QH



BTD-200QH (APC)



Standard accessories

- | | | |
|----|---|-------|
| 1 | Numerical control system TOSNUC 999 | 1 set |
| 2 | Machine operation box (pendant type) | 1 set |
| 3 | Automatic quill clamping unit | 1 set |
| 4 | Spindle orientation stop function | 1 set |
| 5 | Spindle speed drop monitoring function | 1 set |
| 6 | Handwheel feed unit for X-, Y-, Z-, W-, B-axes (portable) | 1 set |
| 7 | Incremental 0.0001° automatic table indexing unit (with rotary scale) | 1 set |
| 8 | Automatic (hydraulic) table clamping unit | 1 set |
| 9 | Table oil pan | 1 set |
| 10 | Saddle slideway cover | 1 set |
| 11 | Bed slideway cover | 1 set |
| 12 | Column front cover | 1 set |
| 13 | Work light (spot light) | 1 set |
| 14 | Assembly and disassembly tools for maintenance | 1 set |
| 15 | Installation parts | 1 set |
| 16 | Automatic main power OFF unit | 1 set |
| 17 | Plug receptacle for external equipment (AC100V, 5A) | 1 set |
| 18 | Hydraulic unit with oil cooler | 1 set |

Special accessories (options) - Set A

- 1 Flood coolant set
 - Lift-up chip conveyor (incorporating a coolant tank)
Mainly used for casting and steel milling chips.
Chip processing capacity 3 ℓ /min (0.78 gal/min)
 - Coil conveyor (built in the bed)
 - Flood coolant unit
Pump capacity 50 ℓ /min, head 5 m (13 gal/min, head 16.4 ft)
Tank capacity 250 ℓ (65 gal)
- 2 Chip cover A
- 3 Operator call lamp (1 color: yellow)

Other special accessories (options)

- 1 Automatic pallet changer
- 2 Spindle nose coolant set (flood coolant type)
Pump master pressure: 1.2 MPa [12 kgf/cm²] (170 psi)
- 3 Spindle nose coolant set (through-tool type)
Pump master pressure: 1.2 MPa [12 kgf/cm²] (170 psi)
- 4 Through-spindle coolant set
Pump master pressure: 1.2 MPa [12 kgf/cm²] (170 psi)
- 5 Through-spindle coolant set
Pump master pressure: 2.0 MPa [20 kgf/cm²] (290 psi)
(A special coolant tank is included.)
- 6 Chip bucket (C)
- 7 Type of retention knob MAS P50T-2 (30°)
- 8 Attached retention knob MAS P50T-1 (45°)
MAS P50T-2 (30°)
- 9 Automatic tool changer
Tool storage capacity: 60, 90
Note) When this specification is selected, required floor space exceeds the standard space.
- 10 Angle head (Type of spindle taper hole: JIS 7/24 taper No.50)
- 11 Automatic measuring function and exclusive touch probe (FM type)
Note) Program storage capacity reduces 50 m (164 ft).
- 12 Calibration block (for automatic measuring function)
- 13 Test bar (60-dia. × 310) [2.36-dia. × 12.2]
- 14 Table edge locators
- 15 B-axis setup compensation function
(Shift of workpiece setup position in B-axis direction is automatically measured and compensated.)
Note) Optional automatic measuring function is required.
- 16 Rotary milling function
- 17 Linear scale feedback X-, Y-, Z-axes
Positioning accuracy ±0.003 mm/Full stroke (±0.00011/Full stroke)
Repeatability ±0.002 mm (±0.00007)
- 18 Z-axis thermal displacement compensation function
- 19 Hydraulic unit pursuant to the Fire Prevention Law
- 20 Operator call lamp (3 colors: red, yellow, green)
- 21 Customer's designated machine exterior painting color
- 22 Block (for tool-type angle head)
- 23 Coolant/air blow unit
Note) Including the spindle nose coolant set (through-tool type)
- 24 Chip air blow unit
- 25 Intermittent coolant unit
- 26 External M code: 8 types
- 27 High-speed spindle (15 ~ 5000 min⁻¹)
- 28 Automatic tool length measuring function
- 29 Master tool (for automatic tool length measuring function)
- 30 Operator side cover (operator side door)
- 31 ATC side cover
- 32 Flex drill
Note) Optional three-dimensional coordinate conversion function is required.

Notes: The air compressor should be provided by the customer.

- (1) Air compressor: Delivery 145 normal liters/min, AC200 V, 1.5 kW (standard)
- (2) Air compressor: Delivery 265 normal liters/min, AC200 V, 2.2 kW (chip air blow)
- (3) Air compressor: Delivery 430 normal liters/min, AC200 V, 3.7 kW (chip air blow + linear scale)

Note : Use a fire-resistant water-soluble coolant



1 Lift-up chip conveyor (set A)



2 Chip cover A (set A)



3 Spindle nose coolant (through-tool type)



6 Chip bucket C



9 60-tool ATC



10 Angle head



11 Automatic measuring function and exclusive touch probe

15 B-axis setup compensation function

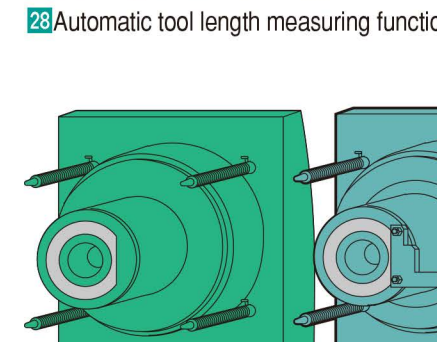

28 Automatic tool length measuring function

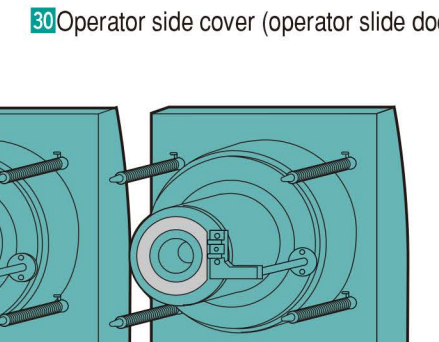

30 Operator side cover (operator slide door)

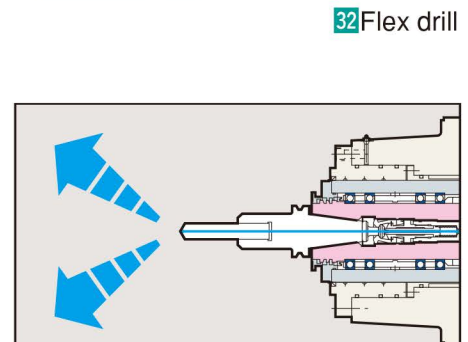

32 Flex drill

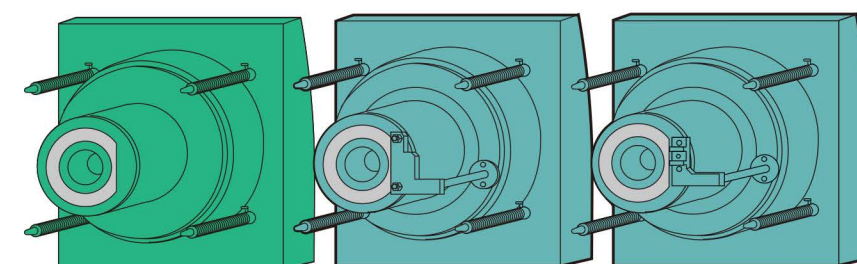

1 Flood coolant (set A)

2 Spindle nose coolant (flood coolant type)

3 Spindle nose coolant (through-tool type)

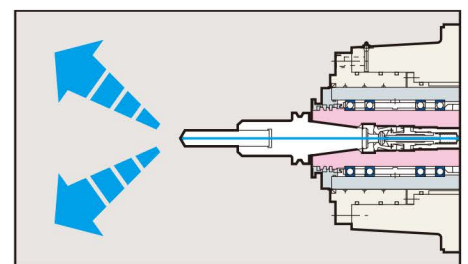

4 5 Coolant through spindle (CTS)

23 Coolant/air blow unit



User media (option set B)

Very useful device for managing long programs.

Pendant operation box

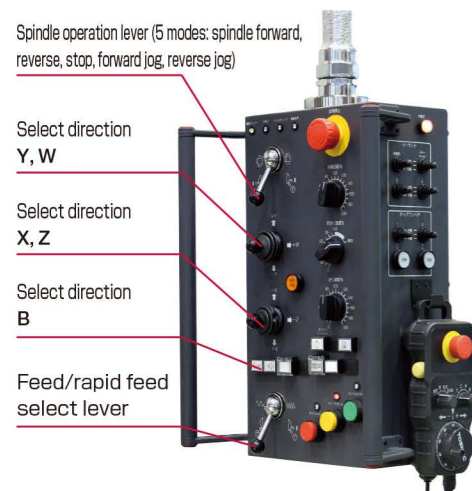

Manual operations relating to machine movements are separated from the NC operation unit and centrally arranged on the pendant operation box. Thus, combined NC and manual machining operations can be performed smoothly.

CNC System Specifications TOSNUC 999

Standard Specifications

●Controlled Axes

Controlled axes 5 axes : X, Y, Z, W, B
Simultaneously controlled axes

3 axes (X, Y, Z) for positioning (G00) and linear interpolation (G01)
2 axes (any two axes excluding W- and B-axes) for circular interpolation (G02, G03)

●Programmable Methods

Programming resolution Linear axis : 0.001 mm
Rotating axis : 0.0001°

Maximum programmable dimension Linear axis : ±99999.999mm
Rotating axis : ±9999.9999°

Data code Automatic recognition of ISO/EIA code
JIS B6311
ISO 6983/1
EIA RS-358-B
EIA RS-244-B

Data format Variable block with a decimal point word address format

Absolute/incremental programming G90/G91
Decimal point input Calculator type/Programming resolution type

●Interpolation

Positioning G00
Linear interpolation G01
Circular interpolation G02/G03: CW/CCW

●Feed

Feedrate F5-digit programming in mm/min
Dwell G04 (0 ~ 999.99 sec)

Handwheel feed (portable)

Linear axis : 0.001/0.01/0.1 mm (per division)
Rotary axis : 0.0001/0.001/0.01° (per division)

Continuous jog feed

Rapid traverse rate override 0 ~ 100% in 10% increments
Feedrate override 0 ~ 200% in 10% increments
Override cancel M48/M49

Automatic acceleration/deceleration

Linear acceleration or deceleration is effected on rapid traverse rate and jog feedrate.
Automatic acceleration/deceleration for feed G08/G09 G50/G51

●Part Program Storage and Edit

Program storage 150 m equivalent punched tape
(To be reduced as per the attached functions.)

No. of registrable programs 128 (To be reduced as per the attached functions.)

Program edit Various editing operations are possible for stored programs.

Background edit

Program deletion, insertion and modification are possible in the background edit mode.

Program name \$(or 0)8-digit programming (alphanumeric characters)
Program comment No. of displayed characters max. 32 (max. 197 for input)

Control in/out

Sequence number N5-digit programming
Sequence number search Bidirectional search is possible.

Program nesting list

Fixture offset list

T-code list

Calendar timer

Program creation date management, time display

●Operation and Display

Operation panel

Display section: 10.4 inch color TFT liquid crystal display
Operation section: Keyboard with membrane switches

Customizing keys

A series of key input operations (key pattern) can be registered. (6 types)
A combination of screens can be registered. (4 types)

Tool file

Tool information such as tool offset and tool name can be batch-displayed and edited.

Automatic operation Memory operation and DNC operation
MDI operation Entry of multiple blocks and restart of an already executed block are possible.

Manual numerical input command

S.F manual setting Setting of S and F codes in manual mode.
S.F auto setting Automatic setting of S and F codes in manual mode.

Spindle drive motor load factor display

Load imposed on spindle drive motor is displayed.

Run hour display

The NC working time is displayed.

Program record A record of programs already executed is displayed.
(Date of program execution, actual time, etc.)

Customized display color tone

Display gray scale of window frame, background and characters can be changed.

●I/O functions and Devices

RS232C interface port A

Operation via external device, loading and dumping of programs and data are possible.

●S, T and M Functions

Spindle speed function S5-digit programming
Spindle speed override 50 ~ 200% (in 10% increments)

Tool function T4-digit programming

Miscellaneous function M4-digit programming

●Tool Offset

Tool length offset G43/G44/(G49)

Tool offset G45/G46/G47/G48

Cutter compensation C G40/G41/G42, point of intersection calculation

No. of tool offsets 60 sets (tool length offset, cutter compensation)

●Coordinate System

Coordinate system setting G92

Machine coordinate system positioning command G73

Plane selection G17/G18/G19

Fixture offset G53/G57, 9 sets

(This function cannot be used together with fixture offset 2.)

Fixture offset 2 G53/G54/G55/G56 3 sets

●Operation Support Function

Single block A program can be executed block by block.

Optional stop

Optional block skip A block containing a “/” code at the head is ignored.

Dry run

Machine lock

Auxiliary function lock

Z-axis feed cancel

Manual absolute ON/OFF

All clear

Reset

Feed hold

Cycle stop

Program restart

Program restart, block restart

Sequence number collation and stop

Manual interruption

Handwheel feed interruption

●Programming Support Function

Circular interpolation by radius R designation

Radius of a circle can be specified directly, using R code.

Circle cutting Inner circle cutting: G12/G13, G22/G23

Outer circle cutting: G222/G223

Canned cycle

G77 ~ G89, G98, G99, G100, G186

Subprogram call G72 (Nesting of up to five levels is possible.)

Macro programming Single call: G72

Modal call 1: G74/G76

Modal call 2: G75/G76

Automatic corner override

Inside corner automatic override

and inside corner cutting speed change.

Pattern cycle G109 ~ G119 (Drilling pattern)

G121 ~ G132 (Milling pattern)

Programming format check function Program format check

Single block suppression G990/G991

Feed hold suppression G992/G993

Override suppression G994/G995

Handwheel feed interruption suppression G996/G997

●Mechanical Error Compensation

Backlash compensation

Pitch error compensation

Pitch error gradient compensation

Origin correction

X-axis shift from table center is corrected.

Unidirectional positioning G60

Straightness compensation

Non-linear type compensation control

●Automatic Support Function

Tool life management

Counting of tool working time

Tool wear coefficient function Tool life and workingtime are counted by multiplying a specified coefficient.

Spare tool selection

●Machine Control Support Function

Integrated PLC TC200

Axis feed interlock

●Safety and Maintenance

Emergency stop

Stored stroke limit

Axis interference area setting and axis interference check

G24/G25, G26/G27

Self-diagnosis function

Door interlock

●Servo System

Servo motor AC servo motors

Position detectors

Absolute encoders (All axes: Absolute position detection)

Rotary scale (B-axis)

Special Specifications (Options)

Options - Set B

(1) Helical interpolation G02/G03 (arc + linear)

(2) Synchronous tapping M843, M844, M845

(3) Part program storage

300 m equivalent punched tape (No. of registrable programs: 256)

(4) User media

(USB port + compact flash slot)

For loading and dumping of NC programs and tool offset data.

(5) No. of fixture offsets

99 sets (including the standard sets)

(6) Random angle chamfering & corner R

(7) Manual alignment function

Including manual tool length/diameter measurement

and coordinate conversion (G10/G11).

(8) Teaching function

Automatic program creation by MDI and manual operations.

(9) W-axis offset function

W-axis extended position is compensated

with Z-axis fixture offset.

Other Options

●Controlled Axes

(1) One additional controlled axis

●Programming Methods

(2) Inch/metric selection G70/G71

●Interpolation

(3) Hypothetical axis interpolation (i.e., interpolation with sine curve) G07

(4) Cylindrical interpolation G67

(5) Involute interpolation G105

(6) Archimedes interpolation (Spiral interpolation) G102/G103

●Feed

(7) Synchronous thread-cutting

(8) Per-revolution feed G95

(9) Per-revolution dwell G05

●Part Program Storage and Edit

(10) Part program storage

600 m equivalent punched tape (No. of registrable programs: 512)

1,200 m equivalent punched tape (No. of registrable programs: 1024)

3,000 m equivalent punched tape (No. of registrable programs: 1024)

5,400 m equivalent punched tape (No. of registrable programs: 1024)

7,800 m equivalent punched tape (No. of registrable programs: 1536)

10,200 m equivalent punched tape (No. of registrable programs: 1536)

(11) Mass memory

Selection of 256 MB, 512 MB or 1 GB.

●I/O Functions and Devices

(12) Remote buffer operation (including port C connection)

(13) High-speed LAN linkage

File transfer by connecting CNC and LAN.

●Tool Offset

(14) No. of tool offsets

No. of tool length offsets: 499 sets (including the standard sets)

No. of cutter compensations: 499 sets (including the standard sets)

(15) Three-dimensional tool compensation G30/G31

●Operation Support Function

(16) Foreground plotting function

A tool locus of active program is plotted.

(17) Additional number of optional block skips Max. 9

●Programming Support Function

(18) Programmable mirror image G62/G66

(19) Programmable data input

Updating of offsets by G58/G59.

(20) Scaling G64/G65

(21) Plane conversion G35 ~ G39

(22) Three-dimensional coordinate conversion G14

(23) Figure copy function G721/G722

(24) Circle cutting compensation

(25) Machining time estimate & NC plotting function

Machining time estimate and tool path plotting

for non-active program on the background.

(26) Pattern cycle division into NC statements

●Automatic Support Function

(27) Faulty cut detection & feedrate regulation function

Tool breakage and wear detection

Feedrate regulation

Note) Counting of tool working time and

spare tool selection are included in

the standard specifications.

(28) Program check & used tool list creation

Check of a program to be executed next

and creation of a slated tool list.

(29) Cutting start detection Used for spot facing, etc.

●Safety and Maintenance

(30) Memory lock

●High-Accuracy Machining & Servo System

(31) Shape recognition preview positioning control

(32) NURBS interpolation

●Cable

(33) RS232C cable 10 m-long